

OneTouch Aluminum Blind

LIMITED LIFETIME WARRANTY

The enclosed product is warranted to the original residential retail purchaser as long as the product remains in the original window.

- I. Covered:
Lifetime: Entire product against manufacturing defects (i.e. a flaw in the product design, materials, or workmanship that causes the product to no longer function)
5 years: All fabric
- II. Not Covered:
Normal Wear and Tear
Any product that fails due to: • abuse • exposure to salt air • improper installation • accident • extraordinary use • improper operation • alterations • improper cleaning • misapplication • damage from pests/insects/pets • improper handling • misuse
- III. Costs associated with: • product removal • transportation to and from the retailer • brand label removal • product re-measure • incidental or consequential damages • product re-installation • shipping
In the event there are multiple blinds/shades in the same room, only the defective blind/shade will be replaced.
- IV. To Report Shipping Damage: If damage occurred during shipping, call place of purchase and report within 7 calendar days or else you may be denied credit for your damaged product.
- V. To Obtain Service: If you suspect this product has a manufacturing defect in materials or workmanship: 1. Locate the sales receipt 2. Call place of purchase. Any unauthorized returns will not be accepted.
- VI. Warranty Remedy: THIS SHALL BE YOUR SOLE REMEDY UNDER THIS LIMITED WARRANTY.
If this product is found to have a manufacturing defect in materials or workmanship, we will (at our discretion) do one of the following:
 - repair the product • replace the product • refund the cost of the product
 Colors vary from lot to lot and may not exactly match sample swatch or previous purchases.
Discontinued items or color selections will be replaced with the closest equivalent current product.
- VII. YOUR RIGHTS UNDER STATE LAW:
This lifetime limited warranty gives you specific legal rights, and you may have other rights, which vary from state to state. Some states do not allow limitations on how long a warranty lasts, so the above limitations may not apply to you. No agent, representative, dealer, or unauthorized employee has the authority to increase or alter the obligation of this warranty. This lifetime limited warranty supersedes any previous versions.

PHASE II PRODUCTS, INC.
501 WEST BROADWAY, SUITE 1350
SAN DIEGO, CALIFORNIA 92101 • 1-800-264-1190

INSTALLATION INSTRUCTIONS

Step 1. Check Package Contents
Missing part? Call 800-264-1190
Mounting hardware kit includes the following:

Part	Quantity
a Mounting Bracket	2 (shades up to 36" wide) 3 (shades 37" to 54" wide) 4 (shades 55" to 72" wide)
b 1 1/8" Screws	2 per bracket

[Note: one extra screw of each noted size is included for convenience]

Step 2. Tools Required

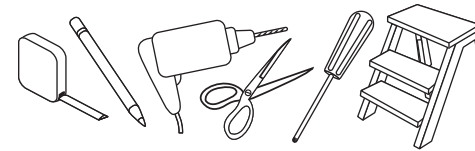

Screwdriver, tape measure, pencil, drill, step ladder, scissor.

Note: use #6 plastic anchors for dry wall or plaster mounting.

Step 3. Bracket Location and Installation

Your blind may be installed either inside the window frame or outside the window frame.

A mounting bracket should be positioned about 1" to 3" from each end of the head rail. For wider shades that require 3 or more brackets, these should be spaced evenly between the two outermost brackets. Always position the brackets such that there is no interference with the mechanisms inside the head rail.

The procedure outlined below will assure proper bracket placement.

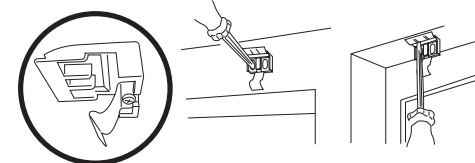

For Outside Mounting:

Clip the brackets onto the head rail as described above. Hold the blind level at the height desired and center it over the window opening. Mark the exact location of each bracket with a pencil. Remove the brackets from the head rail and position the top of each bracket at the marked location and screw each bracket into the wall or window molding using the 1 1/8" screws, pre-drill the screw holes using a 5/64" drill bit.

For Inside Mounting:

Clip the brackets onto the head rail as described above. Hold the blind in place and make a pencil mark at the rear of each bracket where it contacts the inside of the window frame. Remove the brackets from the head rail and align them with the marks. Attach each bracket using the 1 1/8" screws, pre-drill the screw holes using a 5/64" drill bit.

Step 4. Securing the Head Rail

Lift the head rail into position such that the front edge of each bracket is under the inner front edge of the head rail. Push the head rail upward until the flexible tab at the bottom of each bracket snaps onto the back of the head rail. Check carefully to assure that each bracket is properly secured.

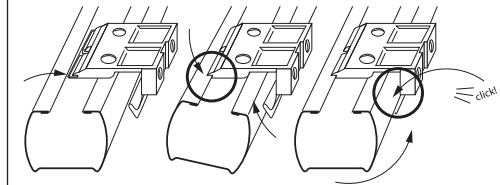

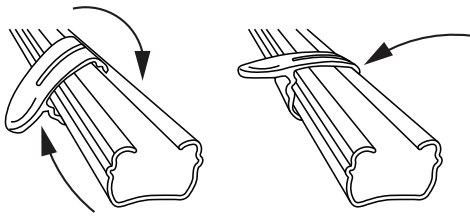

Step 5. Attach Handle / How to Operate

Attach the handle to the bottom rail as illustrated.

To lower blind: Grip the Bottom-Rail/Handle and slowly pull straight down.

To raise blind: Put one hand under the Bottom Rail (palm facing up) and lift with a slow steady tempo until the desired height is reached.

To tilt the slats: Lower and raise the handle slowly. This is a learned technique, but takes only a few seconds to master

Step 6. How to Shorten

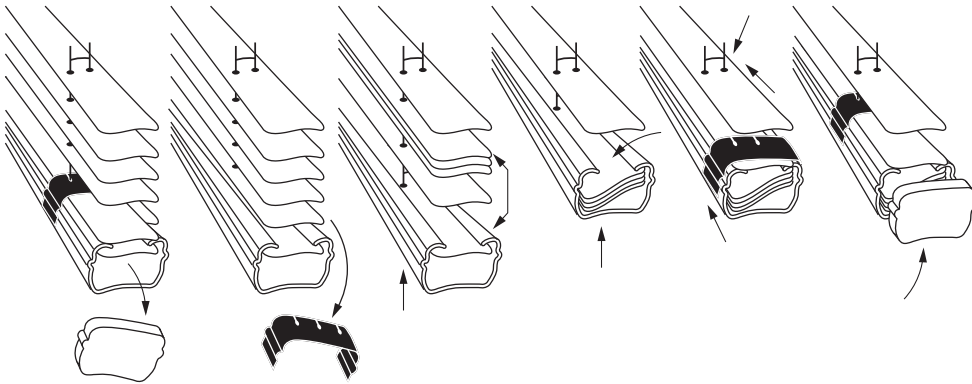

(for ready-made blinds – does not apply to custom blinds)

Your new blind can be shortened up to 10" by following the procedure described and illustrated below. No cutting or re-stringing is required.

Carefully remove the Bottom Rail End Caps and the Slat Clips.

Determine how much you want to shorten the blind (no more than 10") - and then carefully

push the appropriate number of slats into the bottom rail – Hold the bottom rail with one hand and push up slightly as you put no more than 3 or 4 slats at a time inside the bottom rail – a maximum of 12 slats can be placed inside the bottom rail.

Hold a slat directly on top of the bottom rail, and then replace the slat clips and end caps.

CLEANING YOUR BLINDS

Dusting: use a soft cloth, feather duster,

cylindrical dust brushes specifically designed for blinds or vacuum using the soft brush attachment. Washing: use a cloth, sponge or soft brush and a mild detergent.

Use warm or cold water, not hot water.

Place toweling on the floor and/or window sill and wash the blind in sections. Smaller blinds can be washed in a sink or tub; blinds can also be gently hose washed outdoors. Rinse off suds thoroughly. Drain the head rail and bottom rail; remove end caps if necessary. Towel dry to avoid water marks. To have your blinds cleaned professionally, check the local telephone directory for a venetian blind cleaning service or laundry.

REPLACEMENT PARTS

In the event that replacement parts are ever needed, you may Call: 800-264-1190

Please be sure to provide the following information, if possible:

- The complete model or catalog number of your product
- A description of the product
- A description of the part needed